

Flash Auto Stud Light

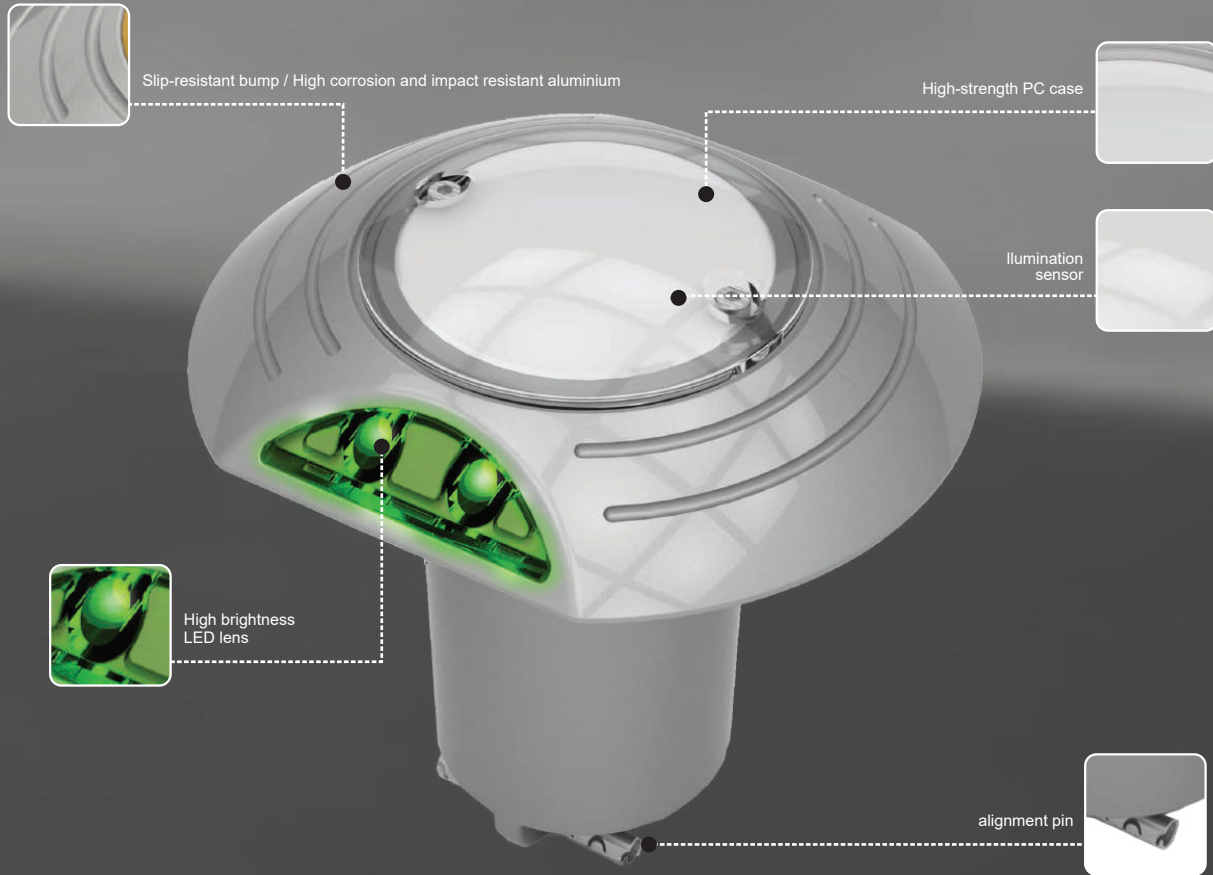

LED luminosity function to create an excellent scenery and a multi-purpose light for pedestrians and drivers

Product Specification			
Item	Spec	Item	Spec
Illumination system	Super Luminosity LED x 4ea	size	W91 X H105 X D104.5
power system	Lithium Battery / 3.6V_19Ahr x 1ea	service life	Lighting: 3years / Flickering : 5years
main material	AL Casting, Polycarbonate (Lens)	weight	500 g
waterproof	IP68	lighting method	Night lights: Operated at sunset 100lx or lower

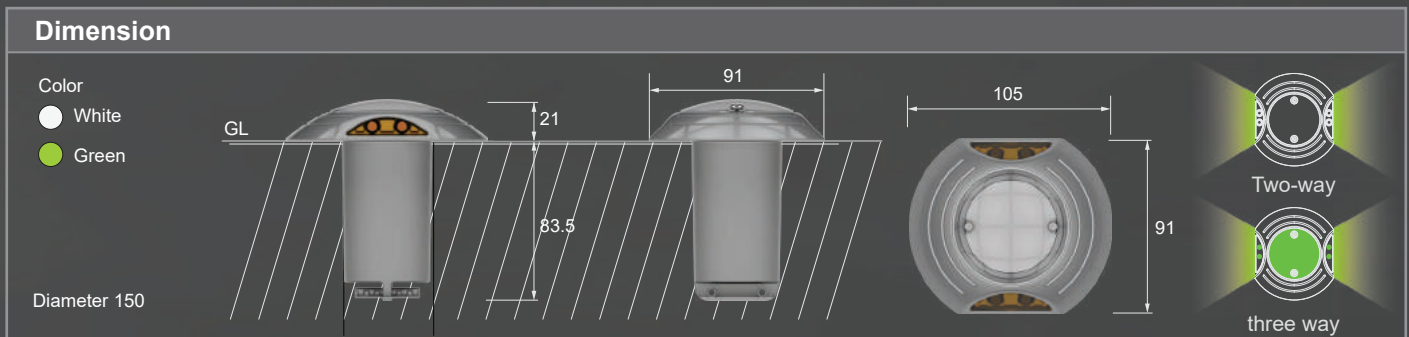

Flash Auto

Item	Code	Type
HB50-BL	23500799	Battery

(Features)

- The battery-powered system has no restrictions on installation conditions.
- High brightness LED offers 100m or higher visibility.
- The smart low-power circuit fulfills a long life.
- Impact-resistant, dust proof and waterproof structure (IP68).



Lighting Angle

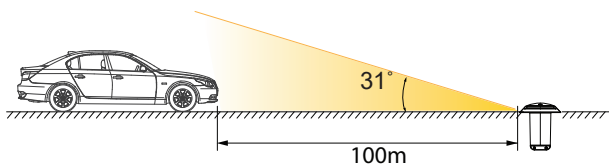

Application

