

LED Safety Bollard

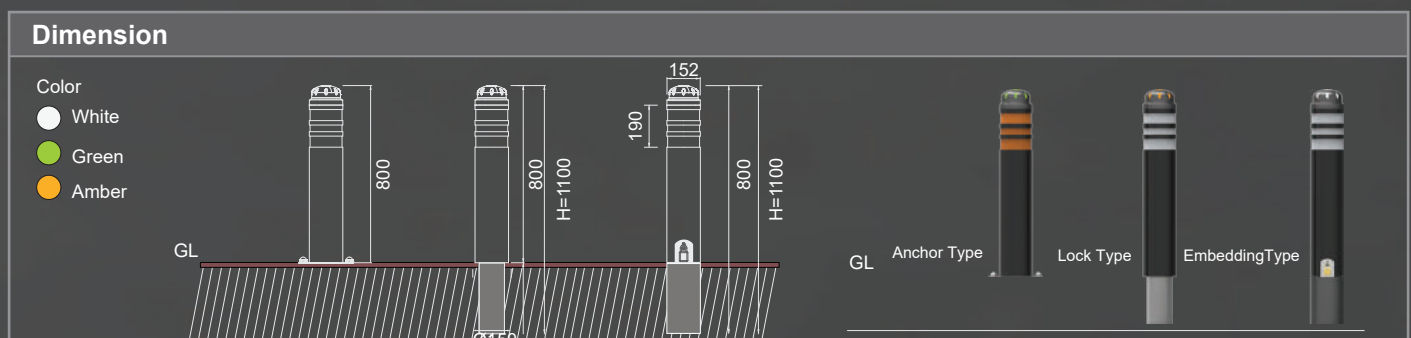

Bollard with luminosity function, reflex function, and urethane cover to protect vehicles and pedestrians

Product Specification			
Item	Spec	Item	Spec
Illumination system	Super Luminosity LED x 9ea	size	Ø152
power system	Lithium Battery / 3.6V_19Ahr x 4ea	service life	Lighting: 5years / Flickering : 10years
main material	AL Casting, Polycarbonate (Lens)	weight	16,000 g
waterproof	IP65	lighting method	Night lights: Operated at sunset 100lx or lower



LED Safety Bollard

Type	Colour	Item	Code
(Anchor)	○	HB20BU-1	23503007
	●	HB20BU-4	23503010
(Lock)	○	HB20BU-2	23503008
	●	HB20BU-5	23503011
(Embedding)	○	HB20BU-3	23503009
	●	HB20BU-6	23503012

(Features)

- The battery-powered system has no restrictions on installation conditions.
- High brightness LED offers 100m or higher visibility.
- The smart low-power circuit fulfills a long life.
- Impact-resistant, dust proof and waterproof structure (IP65).

Distinction between Road and Sidewalk. School Zone. Danger Zone



Reflection sheet Color
 ○ White ● Amber

Application

